

GHGT-11

High efficiency and low cost of electricity generation from fossil fuels while eliminating atmospheric emissions, including carbon dioxide

R.J. Allam^{a*}, Miles R. Palmer^a, G. William Brown Jr.^a, Jeremy Fetvedt^a, David Freed^a, Hideo Nomoto^b, Masao Itoh^b, Nobuo Okita^b, Charles Jones Jr.^c

^aNET Power LLC, 300 Fuller Street, Durham, North Carolina 27701, USA

^bToshiba Corporation, 1-1-1 Shibaura, Minato-ku, Tokyo 105-8001, Japan

^cThe Shaw Group Inc., 4171 Essen Lane, Baton Rouge, LA 70809, USA

Abstract

NET Power has developed a novel, oxy-fuel thermodynamic power cycle [1] that uses hydrocarbon fuels, captures 100% of atmospheric emissions, including all carbon dioxide, and has a cost of electricity that is highly competitive with the best current systems that do not have CO₂ capture. The proprietary system achieves these results through a closed-loop, high-pressure, low-pressure-ratio recuperated Brayton cycle that uses supercritical CO₂ as the working fluid. The cycle exploits the special thermodynamic properties of carbon dioxide as a working fluid by eliminating the energy losses that steam-based cycles encounter due to the heat of vaporization and condensation. The compelling economics of the system are driven by high target efficiencies – 59% net LHV for natural gas and 51% net LHV for coal – and low projected capital and O&M costs, which are the result of utilizing only a single turbine, having a smaller plant footprint, and requiring fewer, smaller components than comparable fossil-fuel systems.

NET Power, Toshiba Corporation, Exelon Corporation, and the Shaw Power Group are partnering to commercialize this system by developing a 50MWt facility that is scheduled to begin testing in 2014. This facility will generate electricity from natural gas and capture 100% of emissions, including all CO₂. The initial design for a commercial system with an electrical output in the range of 200MWt to 500MWt is also under development. The turbine for the 50MWt plant is being designed at the 500MWt level and then scaled down for the demonstration plant to facilitate rapid development of the large-scale turbine in the future. The demonstration plant will test all components and control systems and the operability of the cycle, including 100% capture of carbon dioxide and other impurities, using a range of fuel gas compositions.

The NET Power cycle will have an important impact on the power industry's ability to control and limit greenhouse gas emissions. Driven by its competitive cost when compared to state-of-the-art technologies without CO₂ capture,

* Corresponding author. Tel.: +1-919-667-1800; fax: +1-919-681-0224.

E-mail address: Rodney.Allam@8RiversCapital.com.

the authors believe the NET Power cycle will remove economic barriers to the deployment of 100%-carbon-capture, fossil-fuel-based electricity generation technology. This will enable both the developed and developing world to produce cheap electricity that does not contribute to CO₂-based climate change.

© 2013 The Authors. Published by Elsevier Ltd.

Selection and/or peer-review under responsibility of GHGT

Keywords: CO₂ capture; carbon capture and storage; carbon capture and sequestration; supercritical carbon dioxide; carbon dioxide cycle; enhanced oil recovery; zero emissions; power generation; thermodynamic cycle; supercritical carbon dioxide; oxy-fuel.

1. Introduction

In the face of rising atmospheric CO₂ levels and a continued reliance on fossil fuel-based power generation, new technological solutions are needed [2][3][4]. Renewable energy technologies – based mainly on solar, wind, hydro-electric, and biomass systems – still face difficult cost and reliability challenges [5]. Growth in nuclear power usage has been compromised by recent accidents, the shutdown of old power stations and continued concerns over the storage of nuclear waste. Current greenhouse gas reduction technologies for fossil fuel systems face a difficult future as well. High capital costs, high parasitic energy requirements, and additional environmental concerns over scrubbing chemicals have combined to limit the viability of CO₂ capture systems for fossil fuel power plants [6].

Coupled with these challenges, there has been a dramatic increase in global recoverable natural gas resources and rapid growth in energy usage in the developing world, where coal in particular is a dominant source of energy. Because of these realities, fossil fuels will continue to be relied upon heavily in the immediate future, leading to even greater production of atmospheric CO₂. The result is an accelerating need for technological advancements to achieve low-cost, clean fossil-fuel-based power generation. Broadly, there have been three primary systems proposed and studied extensively for the production of electric power from fossil fuels with CO₂ capture:

- The IGCC system, in which coal is partially oxidized with pure oxygen at high pressure, the produced CO is converted to CO₂ and H₂ by the shift reaction, the H₂ fuel gas is purified with CO₂ capture and the hydrogen fuel is burned in a gas turbine combined cycle power unit.
- Flue gas scrubbing using an amine solvent applied to both coal fired boilers and natural gas combined-cycle power systems.
- Oxy-fuel combustion of a fossil fuel with pure oxygen, producing CO₂ and water plus fuel and combustion-derived impurities followed by separation of pure CO₂. This process has been studied and applied to conventional coal-fired boilers, gas turbine combined cycles, and high pressure steam-based systems.

These systems all face a similar critical problem: they cause significant increases in their cost of electricity over traditional systems, ranging from 33% to 64%, which severely limits their global implementation [7].

NET Power directly addresses this problem by producing fossil-fuel-based electricity without emitting CO₂ to the atmosphere and at a cost that is competitive with current power generation systems that do not have CO₂ capture. This novel cycle separates virtually all of the CO₂ from the other combustion products, producing a sequestration-ready CO₂ byproduct that is at pipeline quality and pressure without degrading

the economic performance of the overall power generation system. This is accomplished with a new high-pressure, closed-loop, oxy-fuel power cycle that utilizes a supercritical CO₂ working fluid, a single high-temperature turbine, an economizer heat exchanger and a novel combustor. The cycle exploits the special thermodynamic properties of carbon dioxide as a working fluid by eliminating the energy losses that steam-based cycles encounter due to the heat of vaporization and condensation. This system achieves very high efficiencies with low capital costs and does not require additional equipment, processes, or costs to capture, purify, and compress produced CO₂.

2. Cycle Process Description

The proprietary NET Power cycle utilizes CO₂ as the working fluid in a high-pressure, low-pressure-ratio Brayton cycle, operating with a single turbine that has an inlet pressure in the range of 200 bar to 400 bar and a pressure ratio of 6 to 12. The cycle includes a high pressure oxy-fuel combustor that burns a fossil fuel in a pure oxygen stream to provide a high pressure feed stream to a power turbine. Figure 1 is a simplified flow scheme for a unit burning natural gas. An economizer heat exchanger transfers heat from the high temperature turbine exhaust flow to a high pressure CO₂ recycle stream that flows into the combustor, diluting the combustion products and lowering the turbine inlet temperature to an acceptable level. The turbine exhaust flow is cooled to a temperature below 70°C in the economizer heat exchanger and then further cooled to near atmospheric temperature in an ambient air cooler or with cooling water. Liquid water derived from water or hydrogen in the fuel is separated, and the remaining stream of predominantly CO₂ is compressed to the required high pressure. The recycle stream is then reheated in the economizer heat exchanger before returning to the combustor. The net CO₂ product derived from the combustion of fuel with pure oxygen in the combustor is removed from the high pressure stream recycle at a high purity and pressure for delivery to an export CO₂ pipeline.

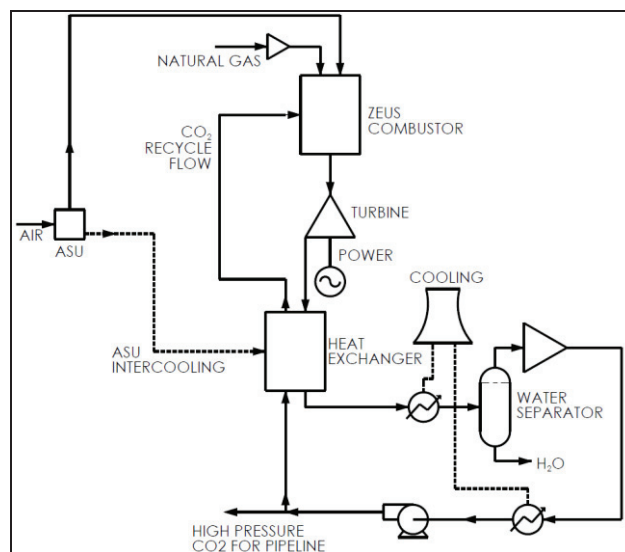

Figure 1: Proprietary NET Power Natural Gas Cycle

The optimum high pressure for operation of the system is between 200 bar and 400 bar, while the optimum pressure ratio is in the range of 6 to 12. This means that the CO₂ recycle compressor inlet pressure will be below the CO₂ critical pressure of 73.9 bar. In the recycle CO₂ compression system, a conventional single- or two-stage compressor first raises the pressure to about 80 bar. The supercritical CO₂ is then cooled to near ambient temperature in the compressor after-cooler. Its density at this point will be above 700kg/m³. The CO₂ can now be pumped to the high pressure required using a multi-stage centrifugal pump.

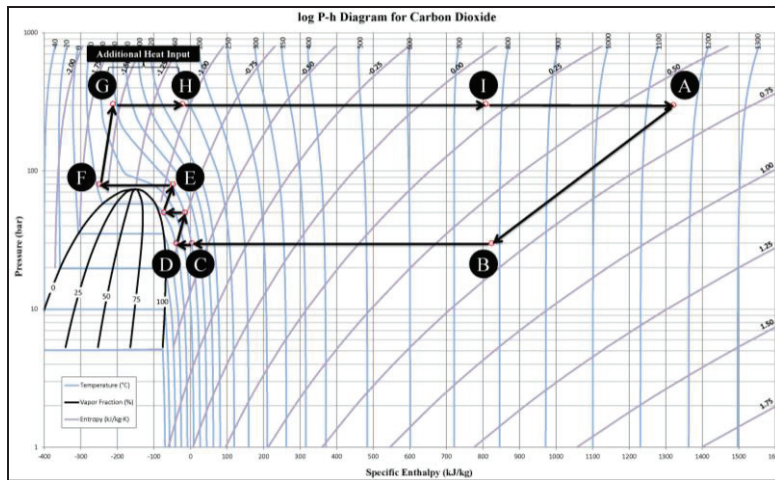

Figure 2: Pressure-Enthalpy Diagram for pure carbon dioxide and the proprietary NET Power natural gas cycle

The operating points for the CO₂ power cycle are shown on a pressure-enthalpy diagram for pure CO₂ in Figure 2. This diagram illustrates a system that uses pure methane as a fuel and has a turbine inlet condition of 300 bar and 1150°C and an outlet pressure of 30 bar. Note that the presence of water, inert nitrogen, argon and oxygen plus fuel and combustion-derived impurities will modify the physical properties slightly. The turbine inlet is at point A and the outlet is at point B, which is also the inlet to the economizer heat exchanger. The heat input to the combustor is equivalent to A-I. The heat transferred from the turbine exhaust to the high pressure recycle stream is B-C. Following ambient cooling from points C to D and water separation, the cooled turbine exhaust enters a two stage CO₂ compressor with an intercooler at point D and is compressed to point E, which is above the critical pressure of the predominantly CO₂ stream. The compressor after-cooler then cools the supercritical CO₂ stream to near ambient temperature at point F. A multi-stage centrifugal pump then raises the CO₂ pressure to the needed high pressure of the recycle stream at point G. The net product CO₂ is removed at or before this point and the remaining stream enters the economizer heat exchanger at point G. The heated recycle CO₂ flow leaves the economizer heat exchanger and enters the combustor at point I, where it mixes with the combustion products from a methane stream burned with oxygen.

To achieve high overall power generation efficiency, a close temperature approach is required at the hot end of the heat exchanger. It can be seen that there is a very significant imbalance between the heat liberated by the low pressure turbine exhaust (B-C) and the heat required to raise the temperature of the high pressure recycle stream (G-I). This imbalance is due to the very large increase in the specific heat of

CO₂ in the high pressure recycle stream at the low temperature end of the economizer heat exchanger (see Table 1)[8].

Table 1: Specific Heat of CO₂ at Various Pressures

Temperature (°k)	CO ₂ at 30 Bar (kJ/kg)	CO ₂ at 300 Bar (kJ/kg)
300	1.18	1.95
350	1.05	2.00
400	1.02	1.90
450	1.03	1.63
500	1.06	1.47
600	1.10	1.31
750	1.17	1.23
1000	1.24	1.28

The imbalance can be corrected by adding a significant quantity of the heat required to raise the recycle CO₂ temperature at the low temperature end of the heat exchanger in a temperature range of 100°C to 400°C. This is done by heating a portion of the recycle CO₂ at point G against an externally generated, low temperature heat source, heating the stream from point G to point H. A very convenient source of heat can come from the air compressors of the cryogenic air separation plant that produces the oxygen stream used in the oxy-fuel combustor. These compressors can be operated adiabatically with no inter-cooling. Although this increases the compressor power, the overall effect on the cycle is very positive since most of the total adiabatic power input to the compressors is matched by an equivalent drop in the fossil fuel energy input needed by the system due to the reduction in the economizer heat exchanger hot end temperature difference.

An important factor in achieving high net cycle efficiency is to use a high turbine inlet temperature. This temperature, however, is limited by the maximum allowable temperature of the low pressure turbine exhaust that flows directly into the heat exchanger. This maximum allowable temperature depends on the operating pressure selected and the allowable stress levels for high nickel alloys, such as Alloy 617, which is approved for ASME rated pressure vessels, including the economizing heat exchanger (see Figure 4) [9]. The operating temperature at the hot end of the heat exchanger is in the range of 700°C to 750°C. This leads to a typical turbine inlet temperature constraint in the range of 1100°C to 1200°C.

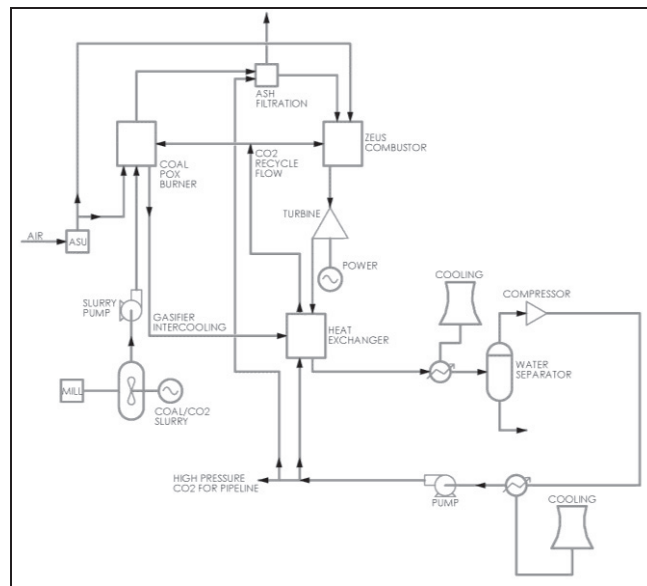

Figure 3: Proprietary NET Power Coal Cycle

Figure 3 shows a coal-fired NET Power system. All the coal- and POX-derived impurities will be present in a reduced form in the synthesis gas product that contains a major quantity of steam and will be in the temperature range of 250°C to 300°C. The water quench, plus the additional water scrub and an addition of a final fine particle filtration, will remove all slag and inorganic material from the steam/fuel gas mixture. The filtered gas stream is then cooled to near ambient temperature in a heat exchanger, which condenses the steam content, cools the fuel gas portion, and transfers the low grade heat released to the low temperature region of the high pressure CO₂ recycle where it is used to heat a side stream from the economizer heat exchanger. There is very little heat loss due to the use of a direct water quench gasifier, since this low grade heat input derived from the sensible heat in the partially oxidized coal-water slurry prior to water quench is available in the NET Power system at close to the same heating value as combusted fuel gas. Condensed water is separated from the fuel gas that is then compressed to the high pressure required for the fuel gas feed to the combustor. The coal-derived fuel gas is combusted and the impurities, such as H₂S, COS, CS₂, NH₃, and HCN, are converted to their oxidized forms: SO₂, NO, H₂O, N₂. The predominant impurities in the low pressure turbine exhaust stream are SO₂ and NO/NO₂. These will be converted to H₂SO₄ and HNO₃ mostly within the cold-end passages of the heat exchanger in the presence of condensed liquid water and excess oxygen. Table 2 shows the reaction sequence. The pressure of the turbine exhaust stream, in the range of 16 bar to 66 bar, ensures that the reaction kinetics are fast. This is particularly true for the NO oxidation reaction, which is accelerated by the relatively high partial pressures of the NO and the excess O₂ present after combustion. This process step has been demonstrated in several locations, including Vattenfall's Schwarze Pumpe pilot plant in Germany. The concentration of H₂SO₄ will depend on the ambient cooling temperature and the sulfur content in the coal used. It should be in the range 10% to 40% by weight. The nitric acid present will largely remove mercury contaminant. The H₂SO₄ can be converted directly to CaSO₄ by reaction with a limestone slurry in a simple stirred tank reactor. Ca(NO₃)₂ is highly soluble in water and can be separately recovered if desired [10].

Table 2: Impurities Reaction Sequence

$\text{NO} + \frac{1}{2} \text{O}_2$	→	NO_2	(1) Slow
2NO_2	→	N_2O_4	(2) Fast
$2 \text{NO}_2 + \text{H}_2\text{O}$	→	$\text{HNO}_2 + \text{HNO}_3$	(3) Slow
3HNO_2	→	$\text{HNO}_3 + 2 \text{NO} + \text{H}_2\text{O}$	(4) Fast
$\text{NO}_2 + \text{SO}_2$	→	$\text{NO} + \text{SO}_3$	(5) Fast
$\text{SO}_3 + \text{H}_2\text{O}$	→	H_2SO_4	(6) Fast

3. Turbine

3.1. General description

The turbine and combustor are new equipment items for this cycle, and their development includes combining gas turbine and steam turbine technologies. The turbine inlet temperature of the cycle is not a high for gas turbines, but it is very high for steam turbines. Similarly, the pressure of this cycle does not surpass that of advanced steam turbines, but it is extremely high for gas turbines. Toshiba has experience with 1300°C gas turbines and combustors, so the NET Power cycle temperature is well within their work experience. Toshiba is also a major developer and manufacturer of steam turbines, having a cumulative production of 170GW to date. In particular, in the area of high pressure and high temperature turbines – USC (Ultra Super Critical) or A-USC (Advanced Ultra Super Critical) – Toshiba has been at the forefront of manufacturing and investment in future technology R&D. The highest pressure achieved to date is 31Mpa (310 bar) for two 700MW turbines in the early 1990s, which continue to be safely operated and whose pressure is still the highest in the world for commercial turbines.

The basic concept of the NET Power turbine is as follows:

- Use well-known, proven technology as much as possible in order to make the R&D scope as minimal as possible.
- Scale down the demonstration turbine from a design of the future commercial plant turbine.

3.2. Material selection

When designing innovative high pressure and/or high temperature turbo-machinery, material R&D is a key focus. For the NET Power turbine, the R&D that Toshiba has conducted for A-USC systems can be effectively utilized. The turbine for the 50MWt demonstration plant of this cycle has a double shell structure (outer casing and inner casing), which is a steam turbine technology that serves to contain the system's high pressure. The space between the inner casing and outer casing will be filled with a carbon dioxide cooling flow extracted from the lower temperature end of the plant. The cooling technology enables the outer casing and first inner casings to be designed using CrMoV casting. Ni-based material is used for the smaller, second inner casing that encloses the exhaust area, where temperatures are higher than 700°C and moderate cooling is applied to the outer surface. As for the rotor, two kinds of materials are being used. The central portion of the rotor uses Ni-based forging. The ends of the rotor, where the temperature is lower and where no moving blades are assembled causing smaller centrifugal force, can utilize CrMoV forging. These two materials will be welded together. In general, very large Ni-based forgings are very difficult to manufacture and require a long R&D period. Additionally, the final product

will typically be very expensive because of the high cost of the material and because of its machining difficulty. Welding the Ni-based forging with the CrMoV forging is a very practical approach that limits the need for Ni-based forging. Toshiba has experience combining Ni-based and CrMoV materials from the R&D of A-USC systems. Figure 4 below shows a comparison of the creep rupture strength of various materials. Conventional materials, including 1% CrMoV in this figure, are used in steam turbine technology. Alloy 617 and Alloy 625 are commercial Ni-based materials. “TOS1X” and “TOS3X” are materials developed by Toshiba; the former is used for forging and the latter is used for casting. It should be noted that Ni-based materials have far stronger characteristics in high temperature regions and that both “TOS1X” and “TOS3X” have even higher creep rupture strength than commercial Ni materials. (NOTE: Product names mentioned above may be trademarks of their respective companies.)

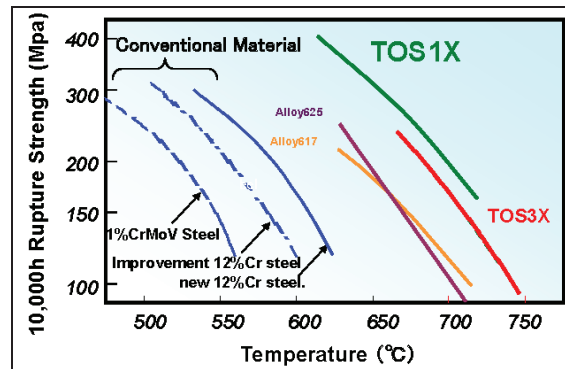

Figure 4: Comparison of Creep Rupture Strength

3.3. Cooling design and thermal barrier coating

In addition to using a welded rotor, the turbine design calls for the use of cooling technology. First, cooling CO_2 is supplied to the center bore of the rotor. This cooling flow is distributed to each stage through radial holes machined in the rotor, which protects both the blade fixation and the moving blade. Figure 5 shows the typical temperature contour of a moving blade in the NET Power turbine; it has been carefully analyzed and takes into account outer heat transfer, inner heat transfer, and thermal conductivity of both the metal and thermal barrier coatings. Film cooling that is generally used for high temperature gas turbine is not necessary in this design because the inlet temperature is not extremely high, as compared to existing gas turbines, and because the heat transfer coefficient of the cooling flow is very high, making simple convection cooling very effective.

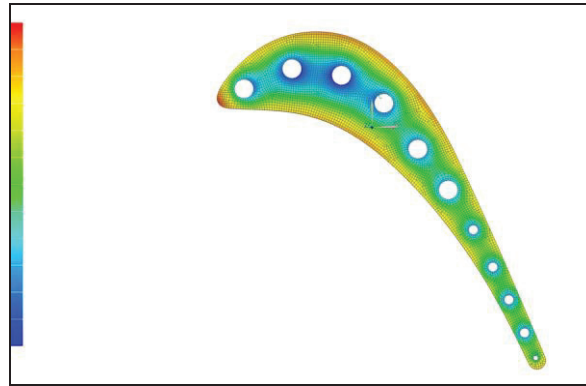

Figure 5: Turbine Blade Temperature Contour

3.4. Combustor

The combustion process in this cycle is of critical importance because the working fluid and pressure is different from typical heavy duty gas turbines. Major characteristics of this combustor are:

- Little to no NO_x emissions because of the use of oxygen as opposed to air.
- The temperature is not as high as existing combustors for heavy duty gas turbines.
- The pressure is much higher than existing combustors.

Recent developments in combustors for heavy duty gas turbine have been focused on decreasing NO_x emissions. This effort has led to the use of “pre-mixed combustion,” in which fuel is mixed with air before combustion to enable lower temperature combustion. The disadvantage of pre-mixed combustion, however, is that it causes system vibrations, called “dynamics,” due to flame instability. In this regard, the present NET Power system is advantageous for combustion because it eliminates NO_x while enabling adoption of simpler and more stable diffusion combustion. The system is also able to use proven cooling technology, such as back side convection cooling, due to the moderate temperature of combustion and the high cooling capability and high availability of carbon dioxide. Toshiba is planning to conduct a high pressure rig test of a NET Power combustor, scaled down by 1:5, at the end of 2012. That test system, shown in Figure 6, will reveal combustion characteristics during simulations of ignition, load-up and operation in order to confirm combustion stability performance, combustion dynamics, temperature distribution, blow-out and other features.

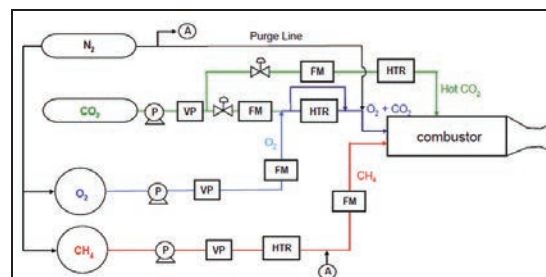

Figure 6: Combustor Test System Design

4. Air Separation

The oxygen required for fuel gas combustion is provided from an industry standard pumped LOX cycle cryogenic air separation unit. An oxygen production rate of approximately 3000 tonne/day at 99.5% purity is required for a 250 MWe NET Power system using natural gas fuel. The oxygen is diluted with a portion of the CO₂ recycle stream before entering the combustor in order to moderate the adiabatic flame temperature. Oxygen concentrations between 15% and 30% by mole-fraction are suitable. The cryogenic air separation system can be designed to produce oxygen at pressures between 30 bar and 80 bar so that it can be blended with CO₂ streams from the suction, inter-stage, or delivery of the CO₂ compressor. A separate O₂/CO₂ compressor delivers the oxidant mixture to the combustor at the required high pressure. It will not be necessary to produce high pressure oxygen directly from the air separation system at pressures above 200 bar. The oxidant mixture is preheated in the economizer heat exchanger before entering the combustor. An oxygen purity of 99.5% results in a net CO₂ product containing about 1% argon and up to 2% oxygen. The main air compressor will be a simple axial flow unit with a discharge pressure of between 5.5 bar and 6 bar. The booster compressor will be a multi-stage centrifugal compressor with a discharge pressure of about 60 bar with the first 2 or 3 stages operated without inter-cooling. The heat of compression from both compressors is transferred to the CO₂ recycle stream using a closed cycle heat transfer fluid. When using coal as the primary fuel, part of the pure oxygen product will be passed directly to the coal gasification reactor.

5. Economizer Heat Exchanger

The NET Power cycle's high efficiency depends on the use of an economizer heat exchanger to recover the sensible heat content of the turbine exhaust, which will be in the range of 700°C to 775°C at 30 bar pressure. The high pressure recycle CO₂ must be heated to a temperature in the range 675°C to 750°C. The very high flows of CO₂ coupled with the large temperature range from 50°C to 750°C require a heat exchanger with a very large specific surface area.

This can be provided by a compact multi-channel plate-fin heat exchanger. This must be fabricated from a suitable grade of stainless steel for the portion up to operating temperatures of 550°C to 600°C and from high nickel alloys, such as "617," for the portion up to 750°C. Heat exchangers with these characteristics are available commercially in stainless steel. The technology for production of the high temperature nickel alloy section can be provided based on development work currently in progress on optimum fabrication techniques.

There are two main types of heat exchanger configuration that can be used for ultra-high pressure service. The first uses passages fabricated from flat metal sheets which are shadow masked with a pattern of the required passages on one side of the metal surface, chemically etched to form the passages, stacked to form a heat exchanger block and diffusion bonded in a heated chamber. The resulting complete heat exchanger block is essentially one continuous metal element with no boundaries present between the passages. This form of construction is well suited to the requirement for high strength and a large surface area per unit of block volume. The necessary nozzles are welded to the blocks and to headers that allow the blocks to be assembled into a battery. High pressure heat exchangers fabricated from stainless steel with this type of construction have been used extensively in the oil industry and recently for experiments in CO₂ heat transfer in nuclear reactor studies.

The second type of surface consists of separately fabricated sections of corrugated sheet metal that forms a finned surface when used in heat exchanger passages. The low pressure passages in the economizer heat exchanger can be fabricated from formed fins that are sandwiched between the high pressure passages. As an alternative to chemical milling to form the high pressure passages, fins held between plain parting sheets can be used. This method of fabrication has been used for gas turbine economizer heat exchangers fabricated from stainless steel. Engineering studies and tests show the suitability of this type of heat exchange fabrication for high pressure and temperatures in both stainless steel and high nickel.

6. Cycle Performance

6.1. Efficiency

Table 3 and Table 4 provide the performance summary and targeted overall efficiency of the NET Power natural gas and coal cycles. The NET Power natural gas system performance is based on pure CH₄ at 40 bar pressure to simulate natural gas fuel. The NET Power coal system is based on Illinois No. 6 coal with 12% water content and a heating value of 22.4 MJ/kg using a conventional partial oxidation water quench gasifier with a water/coal slurry feed. The results demonstrate that NET Power's targeted natural gas efficiency is competitive with current NGCC technologies and the target coal efficiency is superior to that of traditional supercritical pulverized coal and IGCC technologies.

Table 3: NET Power Natural Gas Cycle Target Performance

Natural Gas Target Efficiencies (100% CO₂ Capture at 300 bar)		
Energy Components	HHV	LHV
Gross Efficiency	74.65%	82.70%
CO ₂ Compressor Power	-10.47%	-11.60%
Plant Parasitic Power	-11.01%	-12.20%
Net Efficiency	53.17%	58.90%

Table 4: NET Power Coal Cycle Target Performance

Coal Target Efficiencies (100% CO₂ Capture at 300 bar)		
Energy Components	HHV	LHV
Gross Efficiency	71.12%	74.91%
CO ₂ Compressor Power	-10.25%	-10.78%
Plant Parasitic Power	-11.99%	-12.69%
Net Efficiency	48.88%	51.44%

The turbine inlet and outlet temperatures for the NET Power system are controlled by the temperature and pressure rating for the economizer heat exchanger material at its hot end based on ASME pressure vessel code requirements. The cycle will realize efficiency gains as these temperatures are increased beyond their current level of 1150°C. Recently, alloy 740 with a higher temperature capability has been approved for both piping and pressure vessel use. Future developments in high temperature alloys allowing increases in turbine inlet and outlet temperatures will follow. Additionally, efficiency gains for the air separation plant and compressors, the two largest parasitic loads for the system, will enable overall system efficiency increases.

6.2. Capital cost

Several features of the NET Power system suggest that it will have capital costs that are comparable to or lower than conventional combined cycle or pulverized coal plants. The NET Power cycle eliminates all of the steam elements of a combined cycle system, including the Heat Recovery Steam Generator, main steam piping, reheat steam piping, steam headers, and the entire three stage (HP, IP, LP) steam turbine block. NET Power does include components that are not included in standard combined cycle plants, though, including most notably a heat exchanger and air separation unit. Because of its high pressure, NET Power's cycle is able to utilize smaller components and an overall smaller footprint than plants with a similar power output. Preliminary designs suggest that a NET Power natural gas plant will have a footprint about 1/3 the size of an NGCC plant with a similar power output, and NET Power coal plant will have a footprint about 1/6 the size of a supercritical pulverized coal plant with a similar power output. Additionally, because of its closed-loop, oxy-fuel characteristics, NET Power is able to avoid many of the expensive emissions control systems and components required by conventional fossil fuel plants. The major components of a full-scale commercial NET Power natural gas plant will also be prefabricated, leading to lower site erection costs and a shorter construction schedule compared to existing systems of a similar size.

Capital costs for the NET Power system have been preliminarily evaluated on a rough order of magnitude basis by compiling costs that the system shares with existing, similarly-sized NGCC, IGCC, and Supercritical Pulverized Coal systems, using as a reference the 2010 NETL report: "Cost and Performance Baseline for Fossil Energy Power Plants, Volume 1: Bituminous Coal and Natural Gas to Electricity" [11]. For components not included in similarly sized systems but existing elsewhere (e.g. the heat exchanger and air separation unit), estimates and quotes were compiled from industry reports, design studies, and vendors. This preliminary capital costing analysis resulted in a targeted capital cost of \$800-\$1000/kW for the NET Power natural gas system and a targeted capital cost of \$1500-\$1800/kW for the NET Power coal system. Further granularity and certainly about NET Power's capital costs will be obtained following the completion of a FEED study of the 50MWt NET Power natural gas demonstration plant and a pre-FEED study of a 250MWe natural gas plant, both of which are in progress and being performed by The Shaw Group.

7. Cycle Commercialization

7.1. Development partnership

NET Power LLC, the Shaw Group, Toshiba Corporation, and Exelon Corporation have partnered to commercialize the NET Power system through the development of a 50MWt natural gas power plant. This plant has a final operational goal of continuous operation with no performance degradation. Following initial startup, the plant will go through extensive testing to include demonstration of all components; establishment of start-up and shut-down procedures, ramp rates, and safety and control systems; and measurement of flow stream chemistry and temperatures for future system optimization. Once converted to commercial operation, the plant will generate revenue through sales of electricity and CO₂ for enhanced oil recovery.

The Shaw Group will provide engineering, procurement and construction services to the project. Responsibilities include the development of pre-FEED and FEED studies of the 50MWt demonstration plant and a pre-FEED study of a commercial scale 500MWt NET Power plant. Toshiba is utilizing their experience in both high pressure steam turbines and high temperature gas turbines to develop the NET Power turbine and combustor. Exelon is siting, permitting, and commissioning the facility. NET Power is responsible for management of the project, overall system engineering and integration, and coordination between the partners.

7.2. Development plan, schedule, and progress

NET Power's commercialization will take place in four phases. Phases 1 and 2 include site selection, pre-FEED and FEED studies for the 50MWt natural gas demonstration plant, a pre-FEED study for a 500MWt plant, and a combustor rig-test. These phases are underway and are expected to be completed by the end of 2012. Figure 7 depicts a preliminary layout of the 50MWt demonstration plant. Phase 3, expected to be completed by the end of 2014, involves the delivery of the turbine and other equipment and the construction, commissioning, and testing of the 50MWt plant. In phase 4, the plant will be transitioned to full commercial operation. The development and site selection of the first full-scale commercial natural gas plant in the planned range of a 250MW net electrical capacity is expected to commence in 2014.



Figure 7: 50MWt Preliminary Plant Layout

7.3. Future development plans

The NET Power cycle is a platform technology with a number of applications beyond the basic natural gas-fired and coal-fired configurations. NET Power will pursue a parallel coal development plan that will involve integration with currently available commercial gasifiers. Other important applications of the NET Power cycle will include:

- Integration with Liquefied Natural Gas regasification.
- Integration with existing steam turbine power systems, where the cycle can superheat steam from an existing power station with a coal fired boiler to a temperature of 700°C to 750°C, increasing the overall plant efficiency and power output without increasing net CO₂ emissions.
- Direct integration with Enhanced Oil Recovery facilities.
- Solar-Natural Gas combined cycle plants that utilize concentrated solar power as a heat input to the NET Power system, enabling significant reduction in fuel consumption and near baseload solar power production.

8. Conclusion

The NET Power cycle presents an important opportunity for the power generation sector. In the face of growing climate change impacts from CO₂ emissions, utilizing abundant fossil fuels cleanly without raising the cost of electricity is a critical yet substantial challenge that requires innovative new approaches. By relying on new applications of well-understood technologies, the NET Power cycle can provide a significant breakthrough in oxy-fuel power generation in the near future by offering the first system that eliminates atmospheric CO₂ emissions while competing on all levels with conventional technologies that do not employ carbon capture. The authors believe the technology has the opportunity to make carbon capture an economic choice, even in the absence of carbon regulations, and can enable the widespread adoption of substantially cleaner, low-cost fossil-fuel-based power generation much sooner than previously thought possible.

References

- [1] Allam, John Rodney, et al. System and Method for High Efficiency Power Generation Using a Carbon Dioxide Circulating Working Fluid. Palmer Labs, LLC, assignee. Patent 2011/0179799. 31 Aug 2010.
- [2] Kyoto Protocol to the United Nations Framework Convention on Climate Change, art. 2. UN Doc FCCC/CP/1997/7/Add.1 (Dec. 10, 1997).
- [3] Metz B, Davidson O, de Coninck H, Loos M, Meyer L (Eds). Carbon Dioxide Capture and Storage. Intergovernmental Panel on Climate Change; 2006.
- [4] Hoffert M, et al . Advanced Technology Paths to Global Climate Stability: Energy for a Greenhouse Planet. *Science*, v. 298 (2002), pp. 981-987.
- [5] Brown A, Dobrotova Z, Brown A. Renewable Energy: Markets and Prospects by Technology. International Energy Agency; 2011,
- [6] Finkenrath M. Cost and Performance of Carbon Dioxide Capture from Power Generation. International Energy Agency; 2011.
- [7] *Ibid.*

- [8] Vargaftik NB. *Tables on the Thermophysical Properties of Liquids and Gases in Normal and Dissociated States*. 2nd ed. New York: Halsted Press; 1975, p. 185.
- [9] Li X, Kininmont D, Le Pierres R, Dewson S. “Alloy 617 for the High Temperature Diffusion-Bonded Compact Heat Exchangers”. *Proceedings of ICAPP, Anaheim, 8-12 June 2008*.
- [10] White V, Wright A. “The Vattenfall – Air Products Oxyfuel CO₂ Compression and Purification Pilot Plant at Schwarze Pumpe – Initial Results.” *2nd Oxyfuel Combustion Conference, Yeppoon, Australia, 2011*.
- [11] National Energy Technology Laboratory (2010). *Cost and Performance Baseline for Fossil Energy Plants Volume 1: Bituminous Coal and Natural Gas to Electricity*.